

Syntheses, Reactivity, and π -Donating Ligand Metathesis Reaction of Five-Coordinate Sixteen-Electron Manganese(I) Complexes: Crystal Structures of

$[\text{Mn}(\text{CO})_3(-\text{TeC}_6\text{H}_4\text{-}o\text{-NH})^-]$, $[(\text{Mn}(\text{CO})_3)_2(\mu\text{-SC}_6\text{H}_4\text{-}o\text{-S-S-C}_6\text{H}_4\text{-}o\text{-}\mu\text{-S})^-]$, $[(\text{CO})_3\text{Mn}(\mu\text{-SC}_6\text{H}_4\text{-}o\text{-NH}_2^-)]_2$, and $[(\text{CO})_3\text{Mn}(\mu\text{-SC}_8\text{N}_2\text{H}_4\text{-}o\text{-S})^-]_2^{2-}$

Wen-Feng Liaw,^{*,†} Chien-Kuo Hsieh,[†] Ging-Yi Lin,[†] and Gene-Hsiang Lee[‡]

Department of Chemistry, National Changhua University of Education, Changhua 50058, Taiwan, and Instrumentation Center, National Taiwan University, Taipei 10764, Taiwan

Received July 17, 2000

The preparation of the varieties of five-coordinate sixteen-electron manganese(I) complexes $[\text{Mn}(\text{CO})_3(-\text{EC}_6\text{H}_4\text{-}o\text{-E}')^-]$ (E = Te, Se, S, O; E' = NH, S, O) by (a) oxidative addition of 2-aminophenyl dichalcogenides to anionic manganese(0)-carbonyl, (b) π -donating ligand metathesis reaction of complex $[\text{Mn}(\text{CO})_3(-\text{TeC}_6\text{H}_4\text{-}o\text{-NH})^-]$, and (c) reduction /deprotonation of the neutral dimetallic $[(\text{Mn}(\text{CO})_3)_2(\mu\text{-SC}_6\text{H}_4\text{-}o\text{-S-S-C}_6\text{H}_4\text{-}o\text{-}\mu\text{-S})^-]/[(\text{CO})_3\text{Mn}(\mu\text{-SC}_6\text{H}_4\text{-}o\text{-NH}_2^-)]_2$ proved successful approaches in this direction. The IR ν_{CO} data of the coordinatively and electronically unsaturated $[\text{Mn}(\text{CO})_3(-\text{EC}_6\text{H}_4\text{-}o\text{-E}')^-]$ (E = Te, Se, S, O; E' = NH, S, O) complexes suggest the relative order of π -donating ability of the series of bidentate ligands being $[\text{TeC}_6\text{H}_4\text{-}o\text{-NH}]^{2-} > [\text{SeC}_6\text{H}_4\text{-}o\text{-NH}]^{2-} > [\text{SC}_6\text{H}_4\text{-}o\text{-NH}]^{2-} > [\text{SC}_6\text{H}_4\text{-}o\text{-S}]^{2-} > [\text{SC}_6\text{H}_4\text{-}o\text{-O}]^{2-} > [\text{OC}_6\text{H}_4\text{-}o\text{-O}]^{2-}$. Proton NMR spectra of the $[\text{Mn}(\text{CO})_3(-\text{EC}_6\text{H}_4\text{-}o\text{-NH})^-]$ (E = Te, Se, S) derivatives show the low-field shift of the amide proton (¹H NMR (C₄D₈O): δ 9.66 (br) ppm (E = Te), 9.32 (br) ppm (E = Se), 8.98 (br) ppm (E = S)). The formation of the dimetallic $[(\text{CO})_3\text{Mn}(\mu\text{-SC}_8\text{N}_2\text{H}_4\text{-}o\text{-S})^-]_2^{2-}$ can be interpreted as coordinative association of two units of unstable mononuclear $[(\text{CO})_3\text{Mn}(-\text{SC}_8\text{N}_2\text{H}_4\text{-}o\text{-S})^-]$ and reflects the π -donating ability of the bidentate ligand is responsible for the formation of pentacoordinate, sixteen-electron manganese(I) carbonyl complexes. The neutral bimetallic manganese(I)-bismercaptophenyl disulfide complex $[(\text{Mn}(\text{CO})_3)_2(\mu\text{-SC}_6\text{H}_4\text{-}o\text{-S-S-C}_6\text{H}_4\text{-}o\text{-}\mu\text{-S})^-]$ with internal S–S bond length of 2.222(1) Å and the five-coordinate sixteen-electron complex $[\text{Mn}(\text{CO})_3(-\text{SC}_6\text{H}_4\text{-}o\text{-S})^-]$ are chemically interconvertible. In a similar fashion, treatment of complex $[\text{Mn}(\text{CO})_3(-\text{SC}_6\text{H}_4\text{-}o\text{-NH})^-]$ with HBF₄ yielded neutral dinuclear complex $[(\text{CO})_3\text{Mn}(\mu\text{-SC}_6\text{H}_4\text{-}o\text{-NH}_2^-)]_2$ and showed that the amine deprotonation is reversible. Investigations of π -donating ligand metathesis reactions of complex $[\text{Mn}(\text{CO})_3(-\text{TeC}_6\text{H}_4\text{-}o\text{-NH})^-]$ revealed that the stable intermediate, not the π -donating ability of bidentate ligands, is responsible for the final protonation/oxidation product. This argument is demonstrated by reaction of $[\text{Mn}(\text{CO})_3(-\text{TeC}_6\text{H}_4\text{-}o\text{-NH})^-]$ with 1,2-benzenedithiol, hydroxythiophenol, and catechol, respectively leading to the formation of $[\text{Mn}(\text{CO})_3(-\text{EC}_6\text{H}_4\text{-}o\text{-E}')^-]$ (E = S, O; E' = S, O), although any π -donor containing the amido group is a more effective donor than any other π -donor lacking an amido group. Also, the reactions of $[\text{Mn}(\text{CO})_3(-\text{TeC}_6\text{H}_4\text{-}o\text{-NH})^-]$ with electrophiles occurring at the more electron-rich amide site support that the more electron-rich amide donor of the chelating 2-tellurolatophenylamido occupies an equatorial site as indicated by a shorter Mn^I–N bond length of the distorted trigonal bipyramidal $[\text{Mn}(\text{CO})_3(-\text{TeC}_6\text{H}_4\text{-}o\text{-NH})^-]$.

Introduction

The coordinatively as well as electronically unsaturated iron center coordinated with mixed CO and CN[−] ligands which plays a major role in acting as a binding site for the soft ligand H₂ and in catalyzing reversible activation of H₂ has been observed in the H-cluster of [Fe] hydrogenases.¹ These sixteen-electron coordinatively unsaturated metal–carbonyl complexes have thus attracted recent interest. Preparation of five-coordinate, sixteen-electron, unsaturated metal–carbonyl complexes includes the

following methods: (1) Oxidative substitution of two CO ligands of $[\text{Mn}(\text{CO})_5]^-$ by 3, 5-di-*tert*-butyl-1,2-benzoquinone to give $[\text{Mn}(\text{CO})_3(\text{DBCat})]^{2-}$,² (2) $[\text{W}(\text{CO})_3(-\text{NHC}_6\text{H}_4\text{-}o\text{-NH})]^{2-}$ prepared by the reaction of $\text{W}(\text{CO})_5(\text{THF})$ and 2 equiv of monodeprotonated ligands $[\text{NHC}_6\text{H}_4\text{-}o\text{-NH}_2]^-$ by intermolecular deprotonation,³ (3) $[\text{Cr}(\text{CO})_3(-\text{SC}_6\text{H}_4\text{-}o\text{-S})]^{2-}$ obtained from treatment of bidentate thiolate ligand $[\text{SC}_6\text{H}_4\text{-}o\text{-S}]^{2-}$ and $\text{Cr}(\text{CO})_6$,⁴ and (4) the electrochemical reduction of complexes *fac*- $[\text{Mn}(\text{X})(\text{CO})_3(\text{Pr-DAB})]$ (X = Br, Me; ⁱPr-DAB = 1,4-

* To whom correspondence should be sent.

† National Changhua University of Education.

‡ National Taiwan University

(1) (a) Nicolet, Y.; Piras, C.; Legrand, P.; Hatchikian, C. E.; Fontecilla-Camps, J. C. *Structure* **1999**, 7, 13. (b) Peters, J. W.; Lanzilotta, W. N.; Lemon, B. J.; Seefeldt, L. C. *Science* **1998**, 282, 1853. (c) Pierik, A. J.; Hulstein, M.; Hagen, W. R.; Albracht, S. P. J. *Eur. J. Biochem.* **1998**, 258, 572. (d) Van Dam, P. J.; Reijerse, E. J.; Hagen, W. R. *Eur. J. Biochem.* **1997**, 248, 355. (e) Popescu, C. V.; Münck, E. J. *Am. Chem. Soc.* **1999**, 121, 7877.

(2) (a) Hartl, F.; Vlcek, A., Jr.; deLearie, L. A.; Pierpont, C. G. *Inorg. Chem.* **1990**, 29, 1073. (b) Hartl, F.; Stufkens, D. J.; Vlcek, A., Jr. *Inorg. Chem.* **1992**, 31, 1687.

(3) (a) Darensbourg, D. J.; Klausmeyer, K. K.; Mueller, B. L.; Reibenspies, J. H. *Angew. Chem., Int. Ed. Engl.* **1992**, 31, 1503. (b) Darensbourg, D. J.; Draper, J. D.; Reibenspies, J. H. *Inorg. Chem.* **1997**, 36, 3648. (c) Darensbourg, D. J.; Klausmeyer, K. K.; Reibenspies, J. H. *Inorg. Chem.* **1996**, 35, 1535. (d) Darensbourg, D. J.; Klausmeyer, K. K.; Reibenspies, J. H. *Inorg. Chem.* **1996**, 35, 1529.

(4) Sellmann, D.; Wille, M.; Knoch, F. *Inorg. Chem.* **1993**, 32, 2534.

Scheme 1

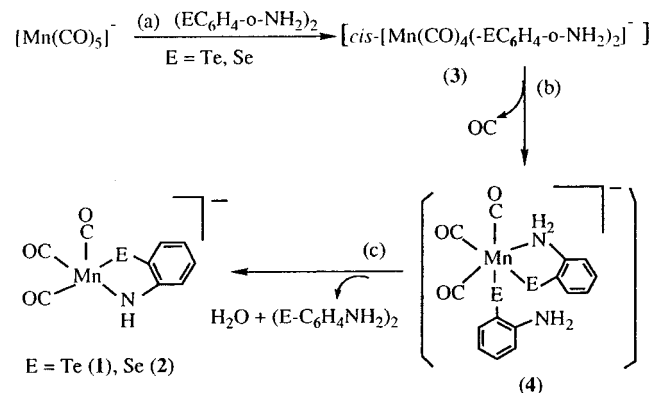

diisopropyl-1,4-diaza-1,3-butadiene) affording the five-coordinate anion $[\text{Mn}(\text{CO})_3(\text{}^i\text{Pr-DAB})]^-$ via dissociation of X^\bullet from the one-electron-reduced intermediate $[\text{Mn}(\text{X})(\text{CO})_3(\text{}^i\text{Pr-DAB})]^-$.

As part of our recent investigations of the pentacoordinate unsaturated manganese carbonyl complexes and biomimetic structural model of the active-site of $[\text{Fe}]$ hydrogenases, we have determined the molecular structures of five-coordinate, sixteen-electron complexes, namely, the manganese(I) and iron(II) derivatives $[\text{Mn}(\text{CO})_3(-\text{SC}_6\text{H}_4\text{-}o\text{-NH-})]^-$,⁶ $[\text{Mn}(\text{CO})_3(-\text{SC}_6\text{H}_4\text{-}o\text{-S-})]^-$,⁷ and $[\text{Fe}(\text{CO})_2(\text{CN})(-\text{SC}_6\text{H}_4\text{-}o\text{-NH-})]^-$.⁸ For the comparison we have sought to synthesize analogues containing π -donating bidentate $[-\text{EC}_6\text{H}_4\text{-}o\text{-NH}]^{2-}$ (E = Te, Se) ligands. Reactivities of the series of these unsaturated $[\text{Mn}(\text{CO})_3(-\text{EC}_6\text{H}_4\text{-}o\text{-NH-})]^-$ (E = Te, Se, S) complexes have been studied. Additional comparison of the stability of the 1,2-benzenedithiolate complex $[\text{Mn}(\text{CO})_3(-\text{SC}_6\text{H}_4\text{-}o\text{-S-})]^-$ with that of its analogue $[\text{Mn}(\text{CO})_3(-\text{SC}_8\text{N}_2\text{H}_4\text{-}o\text{-S-})]^-$ also allows one to understand the influence of π -donating abilities on the structural bonding (coordination) of the $[\text{Mn}(\text{CO})_n]$ moiety. In particular, π -donating ligand metathesis reactions of $[\text{Mn}(\text{CO})_3(-\text{TeC}_6\text{H}_4\text{-}o\text{-NH-})]^-$ in this investigation demonstrate that the stability of intermediate plays a critical role in determining the reaction product (reaction pathway).

Results and Discussion

The chemistry reported herein is summarized in Schemes 1–4. The reaction of 2-aminophenyl dichalcogenide with $[\text{Mn}(\text{CO})_5]^-$ proceeds cleanly in dry THF to form pentacoordinate, sixteen-electron, E,NH-chelated $[\text{Mn}(\text{CO})_3(-\text{EC}_6\text{H}_4\text{-}o\text{-NH-})]^-$ (E = Te (1), Se (2)) via oxidative decarbonylation addition, chelation, oxidation, and deprotonation (Scheme 1a–c).⁹ Compound 1 (compound 2) was isolated as brown solid from THF-hexane in 86% yield (72% yield for 2). Oxidative addition of 2-aminophenyl dichalcogenide to $[\text{Mn}(\text{CO})_5]^-$ yields monodentate (E-bonded) *cis*- $[\text{Mn}(\text{CO})_4(-\text{EC}_6\text{H}_4\text{-}o\text{-NH}_2)_2]^-$ (3) (Scheme 1a).¹⁰ Chelation of one terminal chalcogenolate ligand of intermediate 3 yields the *fac*- $[\text{Mn}(\text{CO})_3(-\text{EC}_6\text{H}_4\text{-}o\text{-NH}_2)(-\text{EC}_6\text{H}_4\text{-}o\text{-NH}_2)]^-$ (4) with one of the anionic $[\text{EC}_6\text{H}_4\text{-}o\text{-NH}_2]^-$

Scheme 2

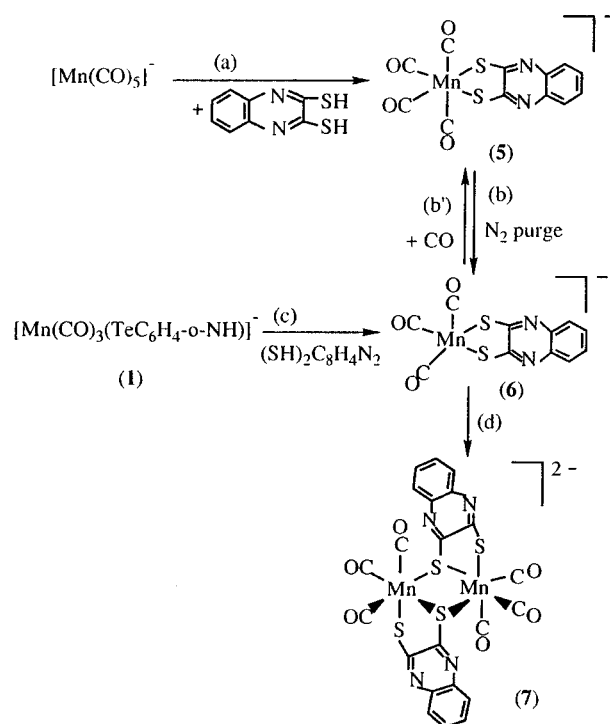

Scheme 3

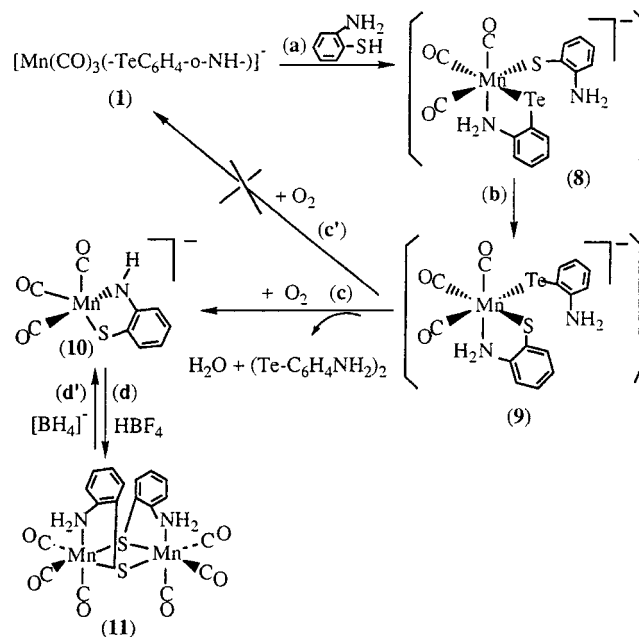

$o\text{-NH}_2]^-$ ligands bound to the Mn^{I} metal in a bidentate manner (E,N-bonded) while the second one is bound to the Mn^{I} metal in a monodentate (E-bonded) manner (Scheme 1b).¹¹ Oxidation (by dry O_2) of the monodentate chalcogenolate ligand and the concomitant deprotonation of amine proton of bidentate chalcogenolate ligand of intermediate 4 leads to formation of complexes 1 and 2 accompanied by byproducts, H_2O and 2-aminophenyl dichalcogenide as identified by ^1H NMR (Scheme

(5) Rossenaar, B. D.; Hartl, F.; Stufkens, D. J.; Amatore, C.; Maisonhaute, E.; Verpeaux, J.-N. *Organometallics* **1997**, *16*, 4675.

(6) (a) Liaw, W.-F.; Lee, C.-M.; Lee, G.-H.; Peng, S.-M. *Inorg. Chem.* **1998**, *37*, 6396. (b) Liaw, W.-F.; Hsieh, C.-K. Unpublished results.

(7) Lee, C.-M.; Lin, G.-Y.; Hsieh, C.-H.; Hu, C.-H.; Lee, G.-H.; Peng, S.-M.; Liaw, W.-F. *J. Chem. Soc., Dalton Trans.* **1999**, 2393.

(8) Liaw, W.-F.; Lee, N.-H.; Chen, C.-H.; Lee, C.-M.; Lee, G.-H.; Peng, S.-M. *J. Am. Chem. Soc.* **2000**, *122*, 488.

(9) (a) Engman, L.; Stern, D.; Cotgreave, I. A.; Andersson, C. M. *J. Am. Chem. Soc.* **1992**, *114*, 9737. (b) Ayyangar, N. R.; Lugade, A. G.; Nikrard, P. V.; Sharma, R. *Synthesis*, **1981**, 640. (c) Battistoni, P.; Bompadre, S.; Bruni, P.; Fava, G. *Gazz. Chim. Ital.* **1981**, *111*, 505.

(10) (a) Liaw, W.-F.; Ou, D.-S.; Li, Y.-S.; Lee, W.-Z.; Chuang, C.-Y.; Lee, Y.-P.; Lee, G.-H.; Peng, S.-M. *Inorg. Chem.* **1995**, *34*, 3747. (b) Liaw, W.-F.; Chuang, C.-Y.; Lee, W.-Z.; Lee, C.-K.; Lee, G.-H.; Peng, S.-M. *Inorg. Chem.* **1996**, *35*, 2530.

(11) Liaw, W.-F.; Chen, C.-H.; Lee, G.-H.; Peng, S.-M. *Organometallics* **1998**, *17*, 2370.

Scheme 4

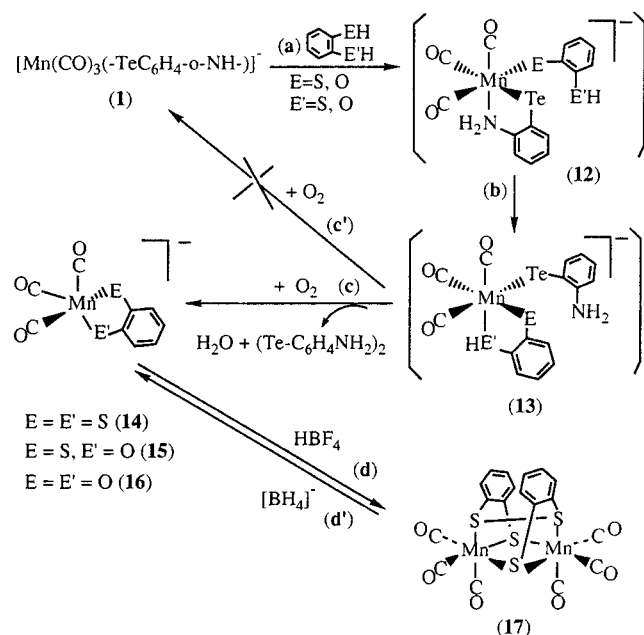

1c).^{6a,12} Complex **1** is stable in THF solution under an inert N₂ atmosphere for 6 days. To our knowledge, it is the first pentacoordinate metal carbonyl complex stabilized by π -donating chelating [TeC₆H₄-o-NH]²⁻/[SeC₆H₄-o-NH]²⁻ ligands.^{3,13}

Proton NMR studies for the series of unsaturated [Mn(CO)₃(-EC₆H₄-o-NH)]⁻ (E = Te, Se, S) complexes suggest the similar geometries, the main difference with the spectra of the [Mn(CO)₃(-EC₆H₄-o-NH)]⁻ derivatives being the low-field shift of the amide proton ([Mn(CO)₃(-EC₆H₄-o-NH)]⁻: δ 9.66 (br) ppm (E = Te), 9.32 (br) ppm (E = Se), 8.98 (br) ppm (E = S) (C₄D₈O)). Also, chelation of [TeC₆H₄-o-NH]²⁻ ligand in the series of [Mn(CO)₃(-EC₆H₄-o-NH)]⁻ complexes causes a decrease of carbonyl stretching frequencies (ν_{CO} (THF): 1966 vs, 1867 s (E = Te); 1971 vs, 1869 s (E = Se); 1973 vs, 1870 s (E = S) cm⁻¹),^{6a} implying the order of π -donating ability [TeC₆H₄-o-NH]²⁻ > [SeC₆H₄-o-NH]²⁻ > [SC₆H₄-o-NH]²⁻ > [SC₆H₄-o-S]²⁻ (the IR $\nu(CO)$ data are known to be excellent probes of the electron-donating ability of the ancillary ligands in metal carbonyl complexes). The relative stability of the series of pentacoordinate sixteen-electron [Mn(CO)₃(-EC₆H₄-o-NH)]⁻ (E = Te, Se, S) complexes is barely discernible.

Figure 1 depicts the structure of complex **1** as an ORTEP; significant bond distances and angles are given in Table 3. The geometry around the Mn(I) center can be loosely defined as trigonal bipyramidal with the electron-rich amide donor of the chelating 2-tellurolatophenylamido occupying an equatorial site. The bite angle of the bidentate 2-tellurolatophenylamido in complex **1** is 84.21(8)°, smaller than that of the chelating 2-thiolatophenylamido in [Mn(CO)₃(-SC₆H₄-o-NH)]⁻ (**10**).^{6a} The significantly shorter Mn^I-Te and Mn^I-N bonds of length 2.556(1) Å and 1.904(3) Å, respectively, in complex **1**, comparing with the reported Mn^I-Te bond of length 2.674(1)

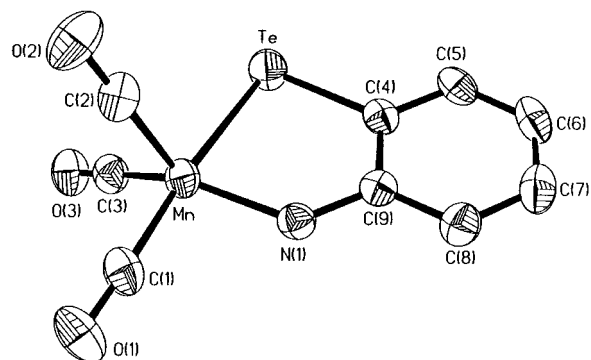

Figure 1. ORTEP drawing and labeling scheme of the [Mn(CO)₃(-TeC₆H₄-o-NH)]⁻ anion with thermal ellipsoids drawn at the 30% probability.

Table 1. Crystallographic Data of Complexes **1** and **7**

	1	7
chem formula	C ₄₅ H ₃₅ N ₂ O ₃ P ₂ MnTe	C ₉₄ H ₆₈ N ₆ P ₄ O ₆ S ₄ Mn ₂
fw	896.23	1739.54
cryst syst	triclinic	triclinic
space group	P1	P1
λ , Å (Mo K α)	0.7107	0.7107
<i>a</i> , Å	9.872(2)	12.5774(3)
<i>b</i> , Å	14.268(3)	13.0335(2)
<i>c</i> , Å	14.428(3)	13.4917(3)
α , deg	89.68(3)	72.485(1)
β , deg	89.08(3)	84.767(1)
γ , deg	81.23(3)	73.453(1)
<i>V</i> , Å ³	2008.2(7)	2021.74(7)
<i>Z</i>	2	1
<i>d</i> _{calcd.} , g cm ⁻³	1.482	1.429
μ , mm ⁻¹	1.163	0.556
<i>T</i> , K	295(2)	150(1)
<i>R</i>	0.0329 ^a	0.0413 ^a
<i>R</i> _w ²	0.0904 ^b	0.0908 ^b
GOF	1.074	1.041

$$^a R = \sum |(F_o - F_c)| / \sum F_o. \quad ^b R_{wF^2} = \{ \sum w(F_o^2 - F_c^2)^2 / \sum [w(F_o^2)^2] \}^{1/2}.$$

Table 2. Crystallographic Data of Complexes **11**·O(C₂H₅)₂ and **17**

	11 ·O(C ₂ H ₅) ₂	17
chem formula	C ₂₂ H ₂₂ N ₂ O ₃ S ₂ Mn ₂	C ₁₈ H ₈ O ₆ S ₄ Mn ₂
fw	600.42	558.36
cryst syst	monoclinic	monoclinic
space group	P2 ₁ /n	P2 ₁ /n
λ , Å (Mo K α)	0.7107	0.7107
<i>a</i> , Å	11.2562(2)	10.6320(1)
<i>b</i> , Å	25.1443(2)	12.4082(3)
<i>c</i> , Å	20.0981(3)	16.6646(2)
α , deg	90	90
β , deg	104.490(1)	94.703(1)
γ , deg	90	90
<i>V</i> , Å ³	5507.41(14)	2191.06(6)
<i>Z</i>	8	4
<i>d</i> _{calcd.} , g cm ⁻³	1.448	1.693
μ , mm ⁻¹	1.109	1.565
<i>T</i> , K	295(2)	295(2)
<i>R</i>	0.0748 ^a	0.0319 ^a
<i>R</i> _w ²	0.1379 ^b	0.0665 ^b
GOF	1.099	1.023

$$^a R = \sum |(F_o - F_c)| / \sum F_o. \quad ^b R_{wF^2} = \{ \sum w(F_o^2 - F_c^2)^2 / \sum [w(F_o^2)^2] \}^{1/2}.$$

(12) (a) Okamura, T.; Takamizawa, S.; Ueyama, N.; Nakamura, A. *Inorg. Chem.* **1998**, *37*, 18. (b) Sellmann, D.; Emig, S.; Heinemann, F. W.; Knoch, F. *Angew. Chem., Int. Ed. Engl.* **1997**, *36*, 1201. (c) Sellmann, D.; Emig, S.; Heinemann, F. W. *Angew. Chem., Int. Ed. Engl.* **1997**, *36*, 1734. (d) Crociani, L.; Tisato, F.; Refosco, F.; Bandoli, G.; Corain, B.; Venanzi, L. M. *J. Am. Chem. Soc.* **1998**, *120*, 2973.

(13) (a) Howard, W. A.; Trnka, T. M.; Parkin, G. *Inorg. Chem.* **1995**, *34*, 5900. (b) Petrie, M. A.; Olmstead, M. M.; Power, P. P. *J. Am. Chem. Soc.* **1991**, *113*, 8704.

Å in *cis*-[Mn(CO)₄(TePh)₂]⁻,^{10a} and Mn⁰-N bond of length 1.981(3) Å in [Mn(CO)₃(TMPO)] (TMPO = 2,2,6,6-tetramethylpiperidinyl-1-oxo),^{2b} were attributed to the strong π -donating ability of the bidentate [TeC₆H₄-o-NH]²⁻ ligand which stabilized the unsaturated complex **1**. The distinct difference of Te-C(4) and N(1)-C(9) distances (2.063(3) and 1.373(4) Å, respectively) in complex **1** vs (Te-C₆H₄NH₂)₂ ligand (2.129-

Table 3. Selected Bond Distances (Å) and Angles (deg) for Complexes **1** and **7**

Complex 1			
Mn–C(2)	1.759(4)	Mn–C(1)	1.778(4)
Mn–C(3)	1.784(4)	Mn–N(1)	1.904(3)
Mn–Te	2.556(1)	Te–C(4)	2.063(3)
N(1)–C(9)	1.373(4)		
C(2)–Mn–C(1)	91.3(2)	C(2)–Mn–C(3)	91.7(2)
C(1)–Mn–C(3)	93.2(2)	C(2)–Mn–N(1)	122.3(2)
C(1)–Mn–N(1)	92.3(2)	C(3)–Mn–N(1)	145.37(14)
C(2)–Mn–Te	94.52(14)	C(1)–Mn–Te	174.14(14)
C(3)–Mn–Te	87.04(12)	N(1)–Mn–Te	84.21(8)
C(4)–Te–Mn	90.35(10)		

Complex 7			
Mn(1)–S(1A)	2.3684(7)	Mn(1)–S(1)	2.4514(7)
Mn(1)–S(2A)	2.3666(7)	Mn(1A)–S(1)	2.3684(7)
Mn(1A)–S(2)	2.3665(7)		
S(1A)–Mn(1)–S(1)	84.58(2)	S(2A)–Mn(1)–S(1A)	86.56(2)
S(2A)–Mn(1)–S(1)	87.89(2)	Mn(1A)–S(1)–Mn(1)	95.42(2)
C(4)–S(1)–Mn(1)	102.15(8)	C(5)–S(2)–Mn(1A)	104.31(8)
C(3)–Mn(1)–S(2A)	175.27(8)	C(1)–Mn(1)–S(1A)	95.41(5)

(3) Å (Te–C, average) and 1.392(5) Å (N–C, average)^{6b} can plausibly be accredited to the delocalized lone pairs of electrons around the five-membered ring (Mn–Te–C–C–NH) in complex **1**. In particular, the Mn^I–N bond length of 1.904(3) Å in complex **1** is longer than that in complex **10** (1.889(3) Å).^{6a}

In contrast, when 2,3-quinoxalinedithiol was reacted directly with [PPN][Mn(CO)₅] in THF at room temperature for 2 days, the hexacoordinate, 18-electron Mn^I complex [Mn(CO)₄(–SC₈N₂H₄-o-S)][–] (**5**) was formed as a dark green semisolid (Scheme 2a). When a THF solution of complex **5** is purged with N₂, the IR ν_{CO} peaks at 2065 w, 1990 s, 1964 m, 1921 m cm^{–1} immediately shifted to 1997 s, 1902 br cm^{–1} indicating formation of pentacoordinate 16-electron Mn^I complex [Mn(CO)₃(–SC₈N₂H₄-o-S)][–] (**6**) (Scheme 2b, 2c).⁷ On bubbling CO through THF solution of complex **6**, carbon monoxide absorption takes place in smooth leading to the hexacoordinate complex **5** (Scheme 2b').

THF solution of complex **6** was stirred for 3 h at room temperature, and then hexane was added to precipitate the dark brown solid [PPN]₂[(CO)₃Mn(μ-SC₈N₂H₄-o-S)]₂ (**7**) (Scheme 2d). Crystals suitable for X-ray crystallography were obtained by diffusion of diethyl ether into its CH₂Cl₂ solution. The IR spectrum of complex **7** in the aprotic solvent CH₂Cl₂ reveals two strong absorption bands for the CO groups at 2005 s, and 1914 br cm^{–1}, as expected for the existence of centrosymmetry (vibrationally uncoupled CO groups on adjacent Mn(I) sites). Obviously, the formation of pentacoordinate, 16-electron manganese(I)-dithiolate carbonyl complexes is particularly sensitive to the appended aromatic heterocycles. The instability of complex **6** can be attributed to the presence of electron-withdrawing N atoms which decrease the π-donating ability of the dithiolate dianion.

The structure of complex **7** is depicted in Figure 2. Selected bond distances and angles are given in Table 3. Complex **7** consists of discrete PPN⁺ cations and [(CO)₃Mn(μ-SC₈N₂H₄-o-S)]₂^{2–} anions. Complex **7** possesses crystallographically imposed centrosymmetry. Two six-coordinate Mn(I) atoms are connected via two thiolate bridges and three pairs of CO groups (C(1)O(1)/C(1A)O(1A), C(2)O(2)/C(2A)O(2A), C(3)O(3)/C(3A)O(3A)) point into the antiparallel direction. The nearly identical Mn(1)–S(1A) and Mn(1)–S(2A) bond lengths of 2.3684(7) and 2.3666(7) Å, respectively, are considerably shorter than the Mn(1)–S(1) bond distance of 2.4514(7) Å in complex

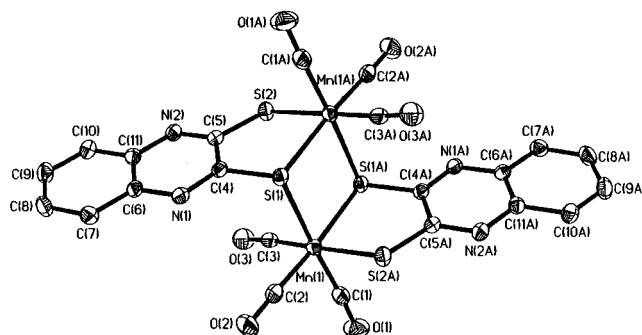
**Figure 2.** ORTEP drawing and labeling scheme of the [(CO)₃Mn(μ-SC₈N₂H₄-o-S)]₂^{2–} anion with thermal ellipsoids drawn at the 50% probability.

7. These differences probably originate from the additional π-donating interactions of the S(1A) and S(2A) with Mn(1) metal center. The longer Mn^I–S bond distance of 2.3675(7) Å (average) in complex **7**, compared to that of pentacoordinate complex [Mn(CO)₃(–SC₆H₄-o-S)][–] (2.230(1) Å average),⁷ also suggests the relative π-donating ability of the dithiolate ligands being [SC₆H₄-o-S]^{2–} > [SC₈N₂H₄-o-S]^{2–}. Formation of complex **7** can also be interpreted as coordinative association of two units of anionic mononuclear [(CO)₃Mn(–SC₈N₂H₄-o-S)][–]. Notably, both the electronic and steric reasons are responsible for the formation of complex **7**.

In contrast to the inert M–N linkages in most transition metal-amide complexes,¹⁴ the d⁶ manganese(I) compound **1** reacts readily with a variety of thiols to give hexacoordinate/pentacoordinate manganese(I)-carbonyl complexes. As illustrated in Scheme 3a–c, treatment of 1 equiv of complex **1** with 2-aminophenyl thiol in THF led to the formation of the known pentacoordinate 16-electron [Mn(CO)₃(–SC₆H₄-o-NH)][–] (**10**) accompanied by byproducts, 2-aminophenyl ditelluride and H₂O as identified by ¹H NMR. Previous work has shown that the formation of pentacoordinate complex **10** occurs via a six-coordinate intermediate containing a bidentate [SC₆H₄-o-NH₂][–] and a monodentate [S–C₆H₄NH₂][–] ligands.⁶ The formation of the pentacoordinate complex **10** from the reaction of complex **1** with 2-aminophenyl thiol was shown in Scheme 3a–c. Reaction may be initiated by protonation of the amide site of complex **1**,¹⁵ followed by the rupture of the Mn^I–NH₂ bond of the chelating [TeC₆H₄-o-NH₂][–] of intermediate **8**, and concomitant chelation of [SC₆H₄-o-NH₂][–] ligand to give intermediate **9**. Upon contact with dry O₂, oxidation of the terminal telluroate ligand and subsequent deprotonation of amine proton of intermediate **9** occurred leading to the formation of complex **10**, along with byproducts 2-aminophenyl ditelluride and H₂O, as verified by ¹H NMR spectroscopy.

The reaction (Scheme 3b) may proceed from the intermediate **8**, perhaps due to better/stable chelating ability of [SC₆H₄-o-NH₂][–] than [TeC₆H₄-o-NH₂][–] in forming a five-membered ring. Specifically, the [SC₆H₄-o-NH₂][–] and [TeC₆H₄-o-NH₂][–] ligands may compete for the Mn orbital. The shorter Mn^I–N as well as Mn^I–S bond lengths (1.889(3) and 2.268(1) Å in complex **10**, respectively) of the bidentate [SC₆H₄-o-NH₂][–] ligand, comparing with Mn^I–N and Mn^I–Te bond distances (1.904(3) and 2.556(1) Å in complex **1**) of [TeC₆H₄-o-NH₂][–] ligand, reflects the fact that chelation of [SC₆H₄-o-NH₂][–] to Mn^I in forming a five-membered chelate ring presumably stabilize the

(14) Nugent, W. A.; Haymore, B. L. *Coord. Chem. Rev.* **1980**, *31*, 123.(15) (a) Michelman, R. I.; Andersen, R. A.; Bergman, R. G. *J. Am. Chem. Soc.* **1991**, *113*, 5100. (b) Michelman, R. I.; Ball, G. E.; Bergman, R. G.; Andersen, R. A. *Organometallics* **1994**, *13*, 869.

intermediate **9**. Obviously, the direction of reaction we have observed for the π -donating ligand metathesis reactions must depend on the formation (stability) of intermediate **9**, i.e., oxidation of intermediate **9** leads to formation of complex **10**, whereas the intermediate **8** was oxidized to form complex **1**. In addition, no fluxional process was observed between intermediates **8** and **9**. The preceding argument has been invoked in Mn^{I} –($EC_6H_4-o-NH_2$) bidentate bonding, and there are no inconsistencies with the π -donating ability guideline ($[EC_6H_4-o-NH]^{2-}$) for predicting the formation (stability) of five-coordinate sixteen-electron manganese(I)-carbonyl complexes.

Under similar reaction condition, pentacoordinate 16-electron $[Mn(CO)_3(-EC_6H_4-o-E')^-]^-$ ($E = E' = S$ (**14**); $E = S, E' = O$ (**15**); $E = E' = O$ (**16**)) was obtained from reaction of complex **1** and 1,2-benzenedithiol (hydroxythiophenol or catechol respectively) in THF at room temperature (Scheme 4a–c) although any π -donor containing the amido group is a more effective than any other π -donor lacking an amido group. Obviously, the preferred (stable) intermediate, not the π -donating ability of bidentate ligands, is responsible for the final protonation/oxidation product. The coordinatively and electronically unsaturated complexes **15**, **16** were unstable with respect to CO loss and decomposed when the solution was allowed to stir at ambient temperature. Attempts to isolate complexes **15**, **16** have thus far been unsuccessful. No reaction was observed when complex **1** was treated with HO-Et and $[NH_2-C_6H_4-o-NH_2]$ respectively. The known bond energy of the O–H bond (87 kcal/mol in phenol) vs the N–H bond (88 kcal/mol in aniline) may explain this observation.¹⁶

The neutral dinuclear Mn(I)-bismercaptophenyl disulfide compound $[(Mn(CO)_3)_2(\mu-SC_6H_4-o-S-S-C_6H_4-o-\mu-S-)]$ (**17**) containing an internal disulfide linkage was prepared in a one-step synthesis by treating complex **14** with HBF_4 (or $[Cp_2Fe][BF_4]$) in THF under N_2 atmosphere at room temperature (Scheme 4d). Complex **17** was isolated as an air-stable brown solid. The formation of complex **17** is presumed to occur via protonation of thiolate, subsequent elimination of H_2 (identified by GC), and concomitant formation of S–S bond (Scheme 4d). Formation of complex **17** can be interpreted as coordinative association of two thiolate-based oxidation fragments $[Mn(CO)_3(-SC_6H_4-o-S-)]$.^{5,17} Complex **14** was reobtained upon chemical reduction of complex **17** with $[PPN][BH_4]$ in THF at room temperature. Apparently, the anionic pentacoordinate complex **14** and the neutral dinuclear complex **17** are chemically interconvertible at room temperature (Scheme 4d,d').

Figure 3 displays an ORTEP plot of the neutral dinuclear complex **17**. The selected bond distances and angles are listed in Table 4. Two six-coordinate Mn(I) atoms are connected via chelating “thiolate, disulfide-bridging” ligand (indicated below). Further appropriate description of the bridging-bonding is that Mn^I atoms were coordinated by a bridging bismercaptophenyl disulfide ligand $[-SC_6H_4-o-S-S-C_6H_4-o-S-]^{2-}$ with S–S bond length of 2.222(1) Å, and facial carbonyl groups. The $Mn(1)-S(3)$ and $Mn(1)-S(4)$ bond lengths of 2.315(1) and 2.379(1) Å, respectively, are considerably shorter than the $Mn(1)-S(1)$ bond distance of 2.423(1) Å in complex **17**. These differences probably originate from the additional π -donating interactions of the S(3) and S(4) with Mn(1) metal center, since the $Mn(1)-S(3)$ and $Mn(1)-S(4)$ distances (2.315(1) and 2.379(1) Å, respectively) in complex **17** are shorter than the terminal

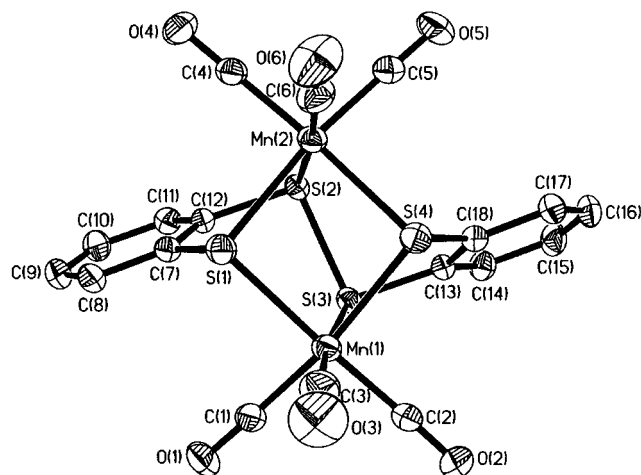
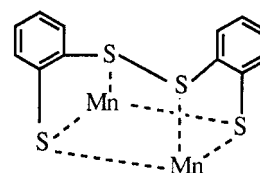

Figure 3. ORTEP drawing and labeling scheme of the neutral dinuclear $[(Mn(CO)_3)_2(\mu-SC_6H_4-o-S-S-C_6H_4-o-\mu-S-)]$ with thermal ellipsoids drawn at the 30% probability.

Table 4. Selected Bond Distances (Å) and Angles (deg) for Complexes **11** and **17**

Complex 11			
Mn(1)–S(2)	2.363(2)	Mn(2)–S(1)	2.364(2)
Mn(1)–N(2)	2.094(5)	Mn(2)–N(1)	2.094(4)
Mn(1)–S(1)	2.435(2)	Mn(2)–S(2)	2.450(2)
C(1)–Mn(1)–N(2)	91.8(3)	N(2)–Mn(1)–S(2)	83.93(14)
C(3)–Mn(1)–S(2)	93.3(2)	N(2)–Mn(1)–S(1)	92.08(13)
C(2)–Mn(1)–S(2)	174.3(2)	N(1)–Mn(2)–S(2)	92.05(12)
C(3)–Mn(1)–S(1)	86.2(2)	S(1)–Mn(2)–S(2)	83.23(5)
N(1)–Mn(2)–S(1)	83.73(12)	S(2)–Mn(1)–S(1)	83.57(6)
Complex 17			
Mn(1)–S(4)	2.379(1)	Mn(2)–S(1)	2.380(1)
Mn(1)–S(3)	2.315(1)	Mn(2)–S(2)	2.314(1)
Mn(1)–S(1)	2.423(1)	Mn(2)–S(4)	2.421(1)
S(2)–S(3)	2.222(1)		
C(3)–Mn(1)–S(3)	173.31(10)	S(3)–Mn(1)–S(4)	82.99(2)
C(2)–Mn(1)–S(4)	94.18(8)	S(3)–Mn(1)–S(1)	95.41(2)
C(1)–Mn(1)–S(4)	171.69(9)	S(2)–Mn(2)–S(1)	83.12(2)
C(2)–Mn(1)–S(1)	175.68(9)	Mn(2)–S(1)–Mn(1)	91.85(2)
C(1)–Mn(1)–S(1)	89.84(8)	C(12)–S(2)–Mn(2)	102.74(8)
S(4)–Mn(1)–S(1)	82.82(2)	C(13)–S(3)–S(2)	95.72(7)
S(2)–S(3)–Mn(1)	102.71(3)	S(1)–Mn(2)–S(4)	82.83(2)

Mn^I –S bond length of 2.398(1) Å (average) in *cis*- $[Mn(CO)_4(SPh)_2]$.¹⁸ The constraints of the bismercaptophenyl disulfide ligand generates (ca. 82.99(2)° S(3)–Mn(1)–S(4) and 83.12(2)° S(2)–Mn(2)–S(1) angles) a severe distortion from octahedron at the hexacoordinate manganese(I) sites.



In contrast, protonation of complex **10** by 1 equiv of HBF_4 in THF under N_2 at room temperature yielded neutral dinuclear hexacoordinate Mn(I)–thiolate carbonyl complex $[(CO)_3Mn(\mu-SC_6H_4-o-NH_2^-)]_2$ (**11**) with two bridging $[SC_6H_4-o-NH_2]^-$ ligands bound to the Mn(I) ion in a bidentate manner (S,N-bonded) individually (Scheme 3d). Obviously, the protonation

(16) McMillen, D. F.; Golden, D. M. *Annu. Rev. Phys. Chem.* **1982**, *33*, 493.

(17) (a) Stiefel, E. I. *J. Chem. Soc., Dalton Trans.* **1997**, 3915. (b) Sellmann, D.; Geck, M.; Moll, M. *J. Am. Chem. Soc.* **1991**, *113*, 5259.

(18) Liaw, W.-F.; Ching, C.-Y.; Lee, C.-K.; Lee, G.-H.; Peng, S.-M. *J. Chin. Chem. Soc. (Taipei)* **1996**, *43*, 427.

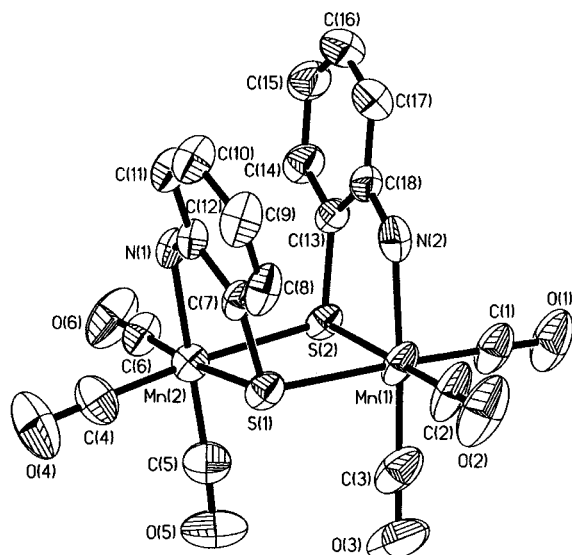

Figure 4. ORTEP drawing and labeling scheme of the neutral dinuclear $[(\text{CO})_3\text{Mn}(\mu\text{-SC}_6\text{H}_4\text{-o-NH}_2\text{-})]_2$ with thermal ellipsoids drawn at the 50% probability.

of complex **10** occurred at the more electron-rich amide site leading to the formation of charge-controlled, collision complex **11**. Formation of complex **11** may be attributed to the avoidance of electron deficiency at the Mn(I) centers as well as to the availability of the nonbonding electron pairs of the sulfur atoms in intermediate $[\text{Mn}(\text{CO})_3(\text{-SC}_6\text{H}_4\text{-o-NH}_2\text{-})]$ obtained from protonation of complex **10**. In a similar fashion, the anionic pentacoordinate complex **10** was reobtained upon addition of 2 equiv of $[\text{Me}_4\text{N}][\text{BH}_4]$ to complex **11** in THF at room temperature. Apparently, the deprotonation of the acidic amine proton of complex **11** results in the formation of the pentacoordinate 16-electron complex **10** (Scheme 3d').

The X-ray crystal structure of complex **11** consists of two crystallographically independent molecules. As can be seen from Figure 4, both the 2-aminophenyl thiolate chelating ligands are on one side of the Mn_2S_2 plane. Each manganese atom is surrounded pseudooctahedrally by two bridging thiolates, one terminal amine, and facial carbonyl groups, with the bite angle of the chelating 2-aminophenyl thiolate being $83.83(14)^\circ$. The nearly identical Mn(1)–S(2) and Mn(2)–S(1) bond lengths of 2.363(2) and 2.364(2) Å, respectively, are considerably shorter than the Mn(1)–S(1) and Mn(2)–S(2) bond distances of 2.435(2) and 2.450(2) Å in complex **11** (Table 4). The terminal Mn^I–NH₂ bond length of 2.094(5) Å (average) in complex **11** is significantly longer than the Mn^I–NH bond length of 1.904(3) Å in complex **1**. The observed carbonyl stretching bands in the IR spectrum are in agreement with the observed structure of complex **11** in which both chelates are on one side of the Mn_2S_2 plane.¹⁹

Conclusion and Comments

The preparation of the varieties of five-coordinate sixteen-electron manganese(I) complexes $[\text{Mn}(\text{CO})_3(\text{-EC}_6\text{H}_4\text{-o-E}'\text{-})]^-$ (E = Te, Se, S, O; E' = NH, S, O) by (a) oxidative addition of 2-aminophenyl dichalcogenides to anionic manganese(0)-carbonyl, (b) π -donating ligand metathesis reaction of complex $[\text{Mn}(\text{CO})_3(\text{-TeC}_6\text{H}_4\text{-o-NH-})]^-$, and (c) reduction/deprotonation of the neutral dimetallic $[(\text{Mn}(\text{CO})_3)_2(\mu\text{-SC}_6\text{H}_4\text{-o-S-S-C}_6\text{H}_4\text{-o-}\mu\text{-S-})]$ proved to be successful approaches.

Scheme 5

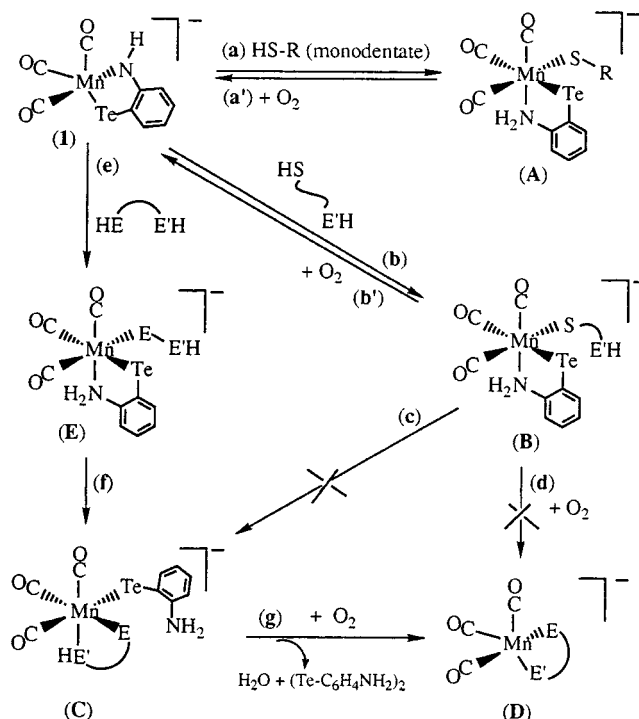

The investigation of π -donating ligand metathesis reaction of complex **1** revealed that the stable intermediate, not the π -donating ability of bidentate ligands, is responsible for the final protonation/oxidation product. This argument is illustrated in Scheme 5.

The ability of a proton donor to precoordinate to the amide site must play a role in these π -donating ligand metathesis reactions. This is particularly apparent when comparing $\text{EtO-H}/[\text{NH}_2\text{-C}_6\text{H}_4\text{-o-NH}_2]$ to the $[\text{SH-C}_6\text{H}_4\text{-o-SH}]$ reagents. The protonation of complex **1** with monodentate alkylthiol (H-SR) proceeded readily to six-coordinate complex **A**, in which the 2-aminophenyl tellurolate ligand is bound in a bidentate mode (Scheme 5a). Complex **A** undergoes facile conversion to the unsaturated complex **1** under O_2 (Scheme 5a'). The results are consistent with oxidation of the monodentate thiolate ligand and concomitant deprotonation of the amine proton of bidentate $[\text{TeC}_6\text{H}_4\text{-o-NH}_2]^-$ ligand (Scheme 5a,a').

Attack of complex **1** by "unfavorable bidentate ligands" $\text{HS}\cdots\text{E}'\text{H}$ (e.g. $\text{HS}(\text{-CH}_2)_3\text{-SH}$, $\text{HS}(\text{-CH}_2)_2\text{-S}(\text{-CH}_2)_2\text{-SH}$,

(19) (a) Abel, E. W.; Dunster, M. O. *J. Chem. Soc., Dalton Trans.* **1973**, 98. (b) Jeannin, S.; Jeannin, Y.; Lavigne, A. G. *J. Cryst. Mol. Struct.* **1977**, 7, 241.

(20) (a) Sellmann, D.; Utz, J.; Heinemann, F. W. *Inorg. Chem.* **1999**, 38, 459. (b) Sellmann, D.; Utz, J.; Heinemann, F. W. *Inorg. Chem.* **1999**, 38, 5314.

HO-(CH₂)₂-SH) generates **B** (Scheme 5b). Conversion of intermediate **B** to **C** was not observed, presumably due to the better chelating ability of [TeC₆H₄-o-NH₂]⁻ than that of [S•••E'H]⁻ (Scheme 5c). As expected, a similar oxidation/deprotonation of thiolate/amine was observed when the complex **B** was treated with dry O₂ resulting in regeneration of complex **1** (Scheme 5b',d). Complex **D** is formed on reacting complex **1** with the "favorable bidentate ligands" HE•••E'H (e.g., [HSC₆H₄-o-SH], [HSC₆H₄-o-NH₂], [HSC₆H₄-o-OH], [HOC₆H₄-o-OH]) (Scheme 5e-g). Specifically, the more stable intermediate (intermediate C) formation, not the π-donating ability of bidentate ligands [EC₆H₄-o-E']²⁻ (E = Te, Se, S, O; E' = NH, S, O), is the major factor governing the reaction product (reaction route) in the π-donating ligand metathesis reaction (Scheme 5).

Also, the reactions of complex **1** with electrophiles occurring at the more electron-rich amide site support that the more electron-rich amide donor of the chelating 2-tellurolatophenyl-amido occupies an equatorial site as indicated by a shorter Mn^I-N bond length of the trigonal bipyramidal complex **1**.^{3,6,7}

Experimental Section

Manipulations, reactions, and transfers of samples were conducted under nitrogen according to standard Schlenk techniques or in a glovebox (argon gas). Solvents were distilled under nitrogen from appropriate drying agents (diethyl ether from CaH₂; acetonitrile from CaH₂-P₂O₅; methylene chloride from P₂O₅; hexane and tetrahydrofuran (THF) from sodium-benzophenone) and stored in dried, N₂-filled flasks over 4 Å molecular sieves. Nitrogen was purged through these solvents before use. Solvent was transferred to reaction vessels via stainless steel cannula under positive pressure of N₂. The reagents dimanganese decacarbonyl, 2-aminophenyl disulfide, 2-aminophenyl diselenide, 1,2-benzenedithiol, 2-aminophenylthiol, hydroxythiophenol, catechol, 1,3-propanedithiol, ferrocenium hexafluorophosphate, bis(triphenylphosphoranylidene)ammonium chloride, fluoroboric acid, and 2,3-quinoxalinedithiol (Lancaster/Aldrich) were used as received. Compound 2-aminophenyl ditelluride was synthesized by published procedures.⁹ Infrared spectra of the carbonyl ν(CO) frequency were recorded on a Bio-Rad Model FTS-185 spectrophotometer with sealed solution cells (0.1 mm) and KBr windows. ¹H and ¹³C NMR spectra were obtained on a Bruker Model AC 200 spectrometer. UV-vis spectra were recorded on a GBC 918 spectrophotometer. Analyses of carbon, hydrogen, and nitrogen were obtained with a CHN analyzer (Heraeus).

Preparation of [PPN][Mn(CO)₃(-EC₆H₄-o-NH-)] (E = Te (1**), Se (**2**)).** The compounds [PPN][Mn(CO)₅] (0.5 mmol, 0.367 g)²¹ and 2-aminophenyl ditelluride (0.5 mmol, 0.220 g) (or 2-aminophenyl diselenide) were dissolved in 4 mL of THF and stirred at ambient temperature. A vigorous reaction occurred with evolution of CO gas. The reaction was monitored with FTIR. IR spectra, 2027 m, 1956 vs, 1946 sh, 1911 m cm⁻¹ (ν_{CO}) (THF) were assigned to the formation of *cis*-[PPN][Mn(CO)₄(-TeC₆H₄-o-NH₂)₂] (**3**). A gentle stream of dry O₂ (about 7 mL) was bubbled through the brown solution. The brown solution completely converted into a dark brown solution accompanied by formation of byproducts, 2-aminophenyl ditelluride and H₂O (identified by ¹H NMR in the separate NMR experiment). The solution was then filtered through Celite, and hexane (10 mL) was added to precipitate the dark brown solid [PPN][Mn(CO)₃(-TeC₆H₄-o-NH-)] (**1**) (dark brown semisolid [PPN][Mn(CO)₃(-SeC₆H₄-o-NH-)] (**2**)). The solid was washed with hexane (5 mL) and recrystallized from THF-hexane (1:5 ratio). The yield of dark brown product **1** was 0.388 g (86%) (72% for complex **2**). Diffusion of hexane into a solution of complex **1** in THF at -15 °C for 4 weeks led to dark brown crystals suitable for X-ray crystallography. Complex **1**. IR ν(CO): 1966 s, 1867 s cm⁻¹ (THF). ¹H NMR (C₄D₈O): δ 9.66 (br) (N-H), 6.40 (t), 6.77

(t), 6.94 (d) ppm (Te-C₆H₄). Absorption spectrum (THF) [λ_{max}, nm (ε, M⁻¹ cm⁻¹): 409(3536), 514(2329). Anal. Calcd for C₄₅H₃₅O₃N₂-TeP₂Mn: C, 60.31; H, 3.94; N, 3.13. Found: C, 59.89; H, 3.93; N, 3.26. Complex **2**. IR ν(CO): 1971 s, 1869 s cm⁻¹ (THF). ¹H NMR (C₄D₈O): δ 9.32 (br) (N-H), 7.69 (d), 7.05 (d), 6.81 (t), 6.55 (t) ppm (Se-C₆H₄). Absorption spectrum (THF) [λ_{max}, nm (ε, M⁻¹ cm⁻¹): 400-(2794), 505(1182). Anal. Calcd for C₄₅H₃₅O₃N₂SeP₂Mn: C, 63.76; H, 4.16; N, 3.31. Found: C, 63.67; H, 4.19; N, 3.30.

Reaction of [PPN][Mn(CO)₅] and 2,3-Quinoxalinedithiol. [PPN][Mn(CO)₅] (0.2 mmol, 0.147 g) and 2,3-quinoxalinedithiol (0.2 mmol, 0.039 g) were dissolved in 3 mL of THF and stirred under nitrogen for 2 days at ambient temperature. Hexane was then added slowly to precipitate a dark green semisolid [PPN][Mn(CO)₄(-SC₈N₂H₄-o-S-)] (**5**). IR ν(CO) (THF): 2065 w, 1990 s, 1964 m, 1921 m cm⁻¹. The complex **5** solution was purged with N₂ (30 min) and monitored with FTIR. IR spectrum, ν(CO) (THF) 1997 s, 1902 s, br cm⁻¹, having the same pattern as, but differing slightly in position from, that of [Mn(CO)₃(-SC₆H₄-o-S-)]⁻ (IR ν(CO) (THF): 1986 s, 1887 br cm⁻¹),⁷ indicated the formation of [PPN][Mn(CO)₃(-SC₈N₂H₄-o-S-)] (**6**). Complex **6** was converted completely to complex **5** on stirring under CO atmosphere for 10 min at room temperature. Attempts to isolate pure complex **5** led to isolation of the mixture of complexes **5** and **6**. After stirring a THF solution of complex **6** for 3 h at 25 °C, hexane was then added to precipitate the dark brown solid [PPN]₂(CO)₃Mn(μ-SC₈N₂H₄-o-S)₂ (**7**). Solvent was removed and dried under vacuum. Then the dark brown complex **7** was recrystallized with CH₂Cl₂-diethyl ether (0.086 g, 48%). Diffusion of diethyl ether into CH₂Cl₂ solution of complex **7** at -15 °C for 2 weeks led to dark brown crystals suitable for X-ray crystallography. IR ν(CO): 2005 s, 1914 br cm⁻¹ (CH₂Cl₂). ¹H NMR (CD₂Cl₂): δ 7.63 (d) (SC₈N₂H₄-o-S), 7.49-7.45 (m) ppm (Ph). Absorption spectrum (CH₂Cl₂) [λ_{max}, nm (ε, M⁻¹ cm⁻¹): 404-(36456), 521(6892), 577(4608). Anal. Calcd for C₉₄H₆₈O₆N₆S₄P₄Mn₂: C, 64.90; H, 3.94; N, 4.83. Found: C, 64.80; H, 4.23; N, 4.76.

Reaction of Complex 1 with 1,2-Benzenedithiol (hydroxythiophenol and catechol, respectively). To a stirred solution of compound **1** (0.090 g, 0.1 mmol) in THF (3 mL) 1,2-benzenedithiol (15 μL, 0.1 mmol) [hydroxythiophenol (10.6 μL, 0.1 mmol) and catechol (0.011 g, 0.1 mmol), respectively] were added under N₂ at room temperature. The reaction solution was stirred for 5 min and monitored by IR. The IR spectrum, ν(CO) 1986 s, 1887 br cm⁻¹ (THF), was assigned to the formation of the known [Mn(CO)₃(-SC₆H₄-o-S-)]⁻ (**14**) (IR ν(CO) spectrum 1990 s, 1890 s, 1881 s cm⁻¹ (THF) assigned to [Mn(CO)₃(-SC₆H₄-o-O-)]⁻ (**15**); IR ν(CO) spectrum 1996 s, 1887 br cm⁻¹ (THF) assigned to [Mn(CO)₃(-OC₆H₄-o-O-)]⁻ (**16**)).^{2,7} Complexes **15** and **16** are extremely unstable. Stirring of the THF solution of complex **15** (**16**) overnight at room temperature led to insoluble decomposition solid. Attempts to isolate complexes **15** and **16** were unsuccessful.

Preparation of [(Mn(CO)₃(μ-SC₆H₄-o-S-S-C₆H₄-o-μ-S-)] (17**).** A portion (35 μL, 0.2 mmol) of HBF₄ (or [Cp₂Fe][PF₆], 0.066 g, 0.2 mmol) was added dropwise by syringe into a CH₂Cl₂ (3 mL) solution of [PPN][Mn(CO)₃(-SC₆H₄-o-S-)] (0.163 g, 0.2 mmol) under N₂ at ambient temperature. A vigorous reaction occurred immediately. The color of the reaction mixture turned from dark red purple to red brown. The reaction was monitored with FTIR (the evolution of H₂ gas was identified by GC). Hexane (10 mL) was added to precipitate the insoluble solid [PPN][BF₄]. The resulting mixture was filtered to remove [PPN][BF₄] and solvent was removed from the filtrate under vacuum. Five milliliters of hexane was added to redissolve the product. Recrystallization from slow evaporation from the concentrated hexane solution (2 mL) gave brown crystals (0.038 g, 68%) at -15 °C, and the crystals were used in the X-ray diffraction study. IR ν(CO): 2041 w, 2022 vs, 1966 m, 1944 m cm⁻¹ (CH₂Cl₂); 2043 w, 2025 vs, 1974 m, 1960 sh, 1952 s cm⁻¹ (hexane). ¹H NMR (C₄D₈O): δ 7.46 (m), 7.70 (d), 8.20 (d) ppm (C₆H₄). ¹³C NMR (C₄D₈O): δ 128.3, 132.8, 133.4 ppm (C₆H₄). Absorption spectrum (THF) [λ_{max}, nm (ε, M⁻¹ cm⁻¹): 390(3325), 485(1989). Anal. Calcd for C₁₅H₈O₃S₄Mn₂: C, 38.69; H, 1.43. Found: C, 38.40; H, 1.53.

Reaction of Complex 17 with [PPN][BH₄]. A solution containing 0.056 g (0.1 mmol) of complex **17** and 0.112 g (0.2 mmol) of [PPN][BH₄] in THF (3 mL) was stirred at ambient temperature for 5 h and monitored by FTIR. The IR spectrum (ν(CO): 1986 s, 1887 br cm⁻¹)

(21) (a) Inkrott, K.; Goetze, G.; Shore, S. G. *J. Organomet. Chem.* **1978**, *154*, 337. (b) Faltynek, R. A.; Wrighton M. S. *J. Am. Chem. Soc.* **1978**, *100*, 2701.

was assigned to the formation of complex [PPN][Mn(CO)₃(-SC₆H₄-*o*-S-)]⁷. The dark purple red product [PPN][Mn(CO)₃(-SC₆H₄-*o*-S-)] was precipitated by addition of diethyl ether and isolated by removing the solvent.

Preparation of [(CO)₃Mn(μ-SC₆H₄-*o*-NH₂-)]₂ (11**).** Compound [PPN][Mn(CO)₃(-SC₆H₄-*o*-NH-)] (0.160 g, 0.2 mmol) was loaded into a 25 mL Schlenk tube, and 3 mL of dry THF was added by cannula under a positive pressure of N₂. Fluoroboric acid (35 μL, 0.2 mmol) was added dropwise by syringe to the dark red solution. After being stirred at ambient temperature for 15 min, diethyl ether (15 mL) was added to completely precipitate [PPN][BF₄]. The resulting mixture was filtered to remove [PPN][BF₄] and solvent was removed from the filtrate under vacuum. The yield of complex **11** was 0.045 g (85%). Recrystallization from saturated diethyl ether solution of complex **11** with hexane diffusion at -15 °C gave brown red crystals (65%). IR ν(CO): 2028 sh, 2005 s, 1933 sh, 1915 vs cm⁻¹ (THF); 2022 s, 2013 vs, 1937 sh, 1920 s cm⁻¹ (CH₂Cl₂); 2031 m, 2012 s, 1941 w, 1920 vs cm⁻¹ (diethyl ether). ¹H NMR (C₄D₈O): δ 4.18 (br), 4.21 (br) (NH₂), 7.08, 7.52, 7.38 ppm (C₆H₄). ¹³C NMR (C₄D₈O): δ 126.0, 131.0, 136.0 ppm (C₆H₄). Absorption spectrum (THF) [λ_{max}, nm (ε, M⁻¹ cm⁻¹): 324-(7115), 345(4655). Anal. Calcd for C₁₈H₁₂N₂O₆S₂Mn₂: C, 41.08; H, 2.30; N, 5.32. Found: C, 41.26; H, 2.21; N, 5.44.

Reaction of Complex 11 with [Me₄N][BH₄]. A solution containing 0.053 g (0.1 mmol) of complex **11** and 0.028 g (0.2 mmol) of [Me₄N][BH₄] in THF (3 mL) was stirred under N₂ for 72 h at room temperature. The IR spectrum (ν(CO): 1973 vs, 1870 s cm⁻¹ (THF)) was identical to that of [Me₄N][Mn(CO)₃(-SC₆H₄-*o*-NH-)]. The product [Me₄N][Mn(CO)₃(-SC₆H₄-*o*-NH-)] was precipitated by adding hexane and isolated by removing the solvent.

Crystallography. Crystallographic data of complexes **1**, **7**, **11**, and **17** are summarized in Tables 1 and 2 and in the Supporting Information. The crystals of **1**, **7**, **11**, and **17** are chunky. The crystals of **1**, **7**, **11**,

and **17** chosen for X-ray diffraction studies measured 0.70 × 0.70 × 0.60 mm, 0.23 × 0.16 × 0.09 mm, 0.30 × 0.25 × 0.20 mm, and 0.50 × 0.30 × 0.28 mm, respectively. Each crystal was mounted on a glass fiber. Diffraction measurement for complex **1** was carried out on Nonius CAD 4 diffractometer and empirical absorption correction from psi scan was made.²² Diffraction measurements for complexes **11** and **17** were carried out at 295(2) K (150(1) K for complex **7**) on a Siemens SMART CCD diffractometer with graphite-monochromated Mo Kα radiation (10.7107 Å) and θ between 1.41 and 25.00° for complex **1**, between 1.58 and 26.37° for complex **7**, between 1.32 and 25.00° for complex **11**, and between 2.05 and 27.49° for complex **17**. Least-squares refinement of the positional and anisotropic thermal parameters for all non-hydrogen atoms and fixed hydrogen atoms contribution was based on *F*². A SADABS²³ absorption correction was made. The SHELXTL²⁴ structure refinement program was employed.

Acknowledgment. We gratefully acknowledge financial support from the National Science Council (Taiwan).

Supporting Information Available: X-ray crystallographic file in CIF format for the structure determinations of [Mn(CO)₃(-TeC₆H₄-*o*-NH-)]⁻, [(Mn(CO)₃)₂(μ-SC₆H₄-*o*-S-S-C₆H₄-*o*-μ-S-)], [(CO)₃Mn(μ-SC₆H₄-*o*-NH₂-)]₂, and [(CO)₃Mn(μ-SC₈N₂H₄-*o*-S)]₂²⁻. This material is available free of charge via the Internet at <http://pubs.acs.org>.

IC000795A

- (22) North, A. C. T.; Philips, D. C.; Mathews, F. S. *Acta Crystallogr.* **1968**, *A24*, 351.
- (23) Sheldrick, G. M. *SADABS, Siemens Area Detector Absorption Correction Program*; University of Göttingen: Germany, 1996.
- (24) Sheldrick, G. M. *SHELXTL, Program for Crystal Structure Determination*; Siemens Analytical X-ray Instruments Inc.: Madison, WI, 1994.